



**Streetfighter
V4 2023**

FITTING INSTRUCTIONS

TO BE FITTED BY A QUALIFIED TECHNICIAN



THIS SHEET INCLUDES FITTING INSTRUCTIONS FOR THE FOLLOWING PARTS:

Secondary Alternator Cover Part No. EC-V4S-SF-2020-1-GBR / Secondary Clutch Cover Part No. EC-V4-SF-2023-2-GBR

Brake & Clutch Lever Guard Part No. BLG-14-A160-GBR / CLG-14-A160-GBR



SECONDARY ALTERNATOR COVER PART NO. EC-V4S-SF-2020-1-GBR

- 1 Remove the 4 standard bolts as shown as bolt position 1, 2, 3 & 4.
- 2 Place the secondary alternator cover against the standard alternator.
- 3 Insert the 4 supplied bolts and tighten to a maximum of 8Nm.

DO NOT OVERTIGHTEN

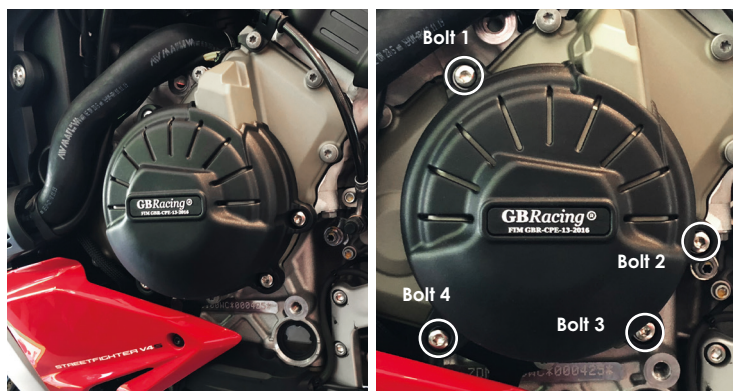

Bolt 1
M6X30A2-TORX - 10Nm

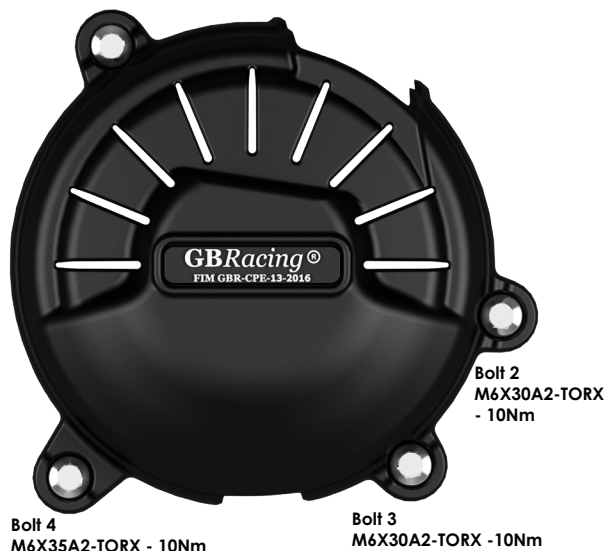

Bolt 2
M6X30A2-TORX - 10Nm

Bolt 4
M6X35A2-TORX - 10Nm

Bolt 3
M6X30A2-TORX - 10Nm

SECONDARY CLUTCH COVER PART NO. EC-V4-SF-2023-2-GBR

- 1 Remove 4 existing bolts from the Clutch cover, shown as position Bolt 1, 2, 3 & 4.
- 2 Place the Secondary Clutch Cover over the stock cover.
- 3 Assemble 4 replacement bolts loosely in the correct position as shown.
- 4 Tighten to a maximum Torque of 8Nm. DO NOT OVERTIGHTEN.

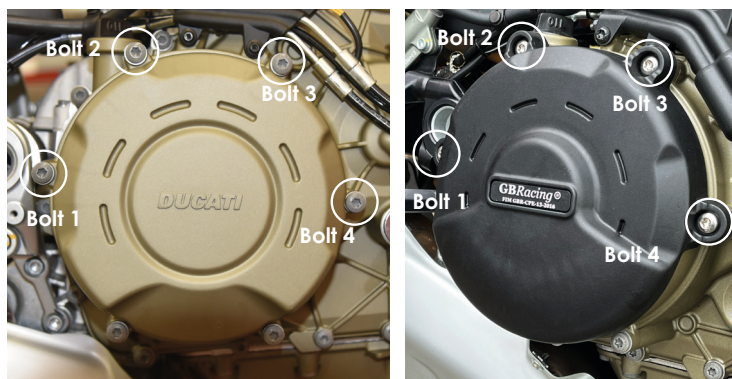

Bolt 2
M6X30A2-TORX - 10Nm (max)

Bolt 3
M6X30A2-TORX - 10Nm (max)

Bolt 1
M6X30A2-TORX - 10Nm (max)

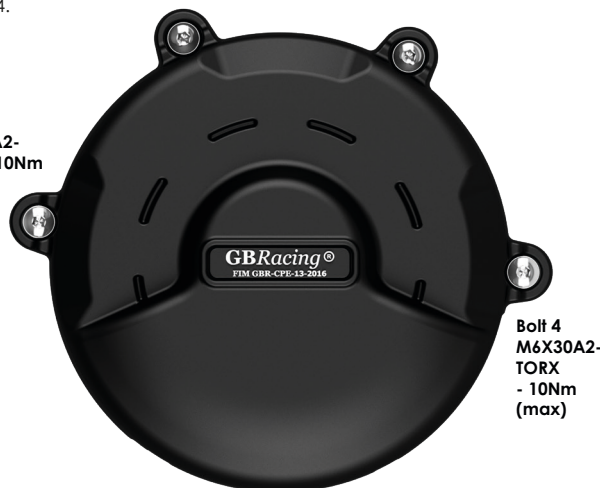

Bolt 4
M6X30A2-TORX - 10Nm (max)

ENGINE COVER SET: Part No. EC-V4-SF-2023-SET-GBR:

EC-V4S-SF-2020-1-GBR, EC-V4-SF-2023-2-GBR



Streetfighter
V4 2023

FITTING INSTRUCTIONS

TO BE FITTED BY A QUALIFIED TECHNICIAN



UNIVERSAL BRAKE LEVER GUARD WITH 14mm INSERT (Fits tube inside diameters from 13.6mm to 15.7mm)

PART NO. BLG-14-A160-GBR

- 1 Remove existing bar end and replacing it with supplied bar end.
- 2 Tighten bolt until the lever protector is tight and does not move up or down under normal pressure.
- 3 Do not ride if you are unsure if it is tight enough and always get a trained technician to confirm.

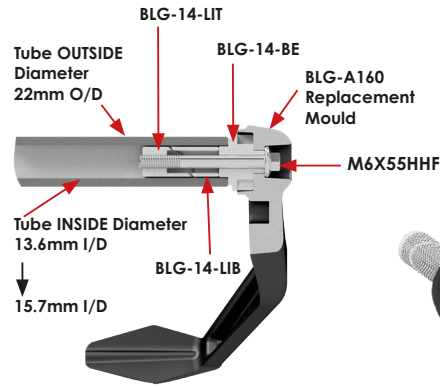

UNIVERSAL CLUTCH LEVER GUARD WITH 14mm INSERT (Fits tube inside diameters from 13.6mm to 15.7mm)

PART NO. CLG-14-A160-GBR

- 1 Remove existing bar end and replacing it with supplied bar end.
- 2 Tighten bolt until the lever protector is tight and does not move up or down under normal pressure.
- 3 Do not ride if you are unsure if it is tight enough and always get a trained technician to confirm.

